

Wholesale-retail -agent

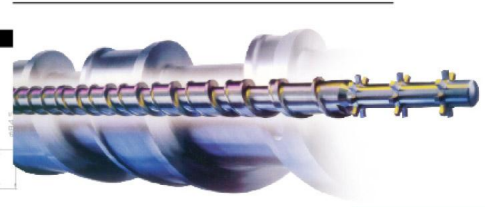

Lower your cost
bring u more benfit

High capacity • Long lifespan • Low consumption



Let clients be our brand's spokesperson !

The reason to be chosen by world top 500 PLASTIK enterprises



We can provide high quality spare

parts – screw for below plastic machine brand

COMPANY PROFILE

目录 Contents













Zhoushan DEMAJI Industrial is specialized in the production of series double screw & barrel, with its huge scale production and excellent equipment, technology, science, well made, strong technical force, we not only provide fittings of machines to foreign and national machinery plants, but also undertakes processing according to the samples by fragmentary. We do global sales such as Russia, India, Korea, Turkey, Middle-East and so on. In line with the policy "save resources for the country, enlarge profits for customers, create benefit and harmonious development for social prosperity", DEMAJI staff after continuous efforts and Sweden engineers cooperate with research, in the original PTA nickel alloy spray welding technology improvement and the development of a long wear-resisting, high corrosion resistance of the two big quality series screw. In a foreign country, high corrosion, high fill PVC, sheet, pipe, sheet material, profiles, wood and plastic, hang wall board, etc. the quality of our exclusive market screw to super durable service life corner the market Wells. The company strictly through ISO9001: 2000 quality management system, the product after the famous at home and abroad for a long time and use plastic enterprise national authority test center and the detection experts gradually assess its technical indexes to attain and more than the international standard.



ISO9001

GBT9001-2000

Material Application and mechanical property	01-04	
Screw For Injection Molding Machine	05-08	
Screw & Barrel For Single Screw Extruder	09-12	
Conical Twin Screw & Barrel	13-16	
Parallel Twin Screw & Barrel	17-20	
Rubber Screw	21-21	
Planetary Screw Barrel	22-22	
Gearboxes series	23-24	
Heater spare parts	25-26	
The Bimetallic Screw And Barrel	27-32	
Advanced Equipment	33-34	



Blanking ▶

Rough Machining ▶

Quenching And Tempering ▶

Semi Finishing Machining ▶

Finish Machining ▶

Nitriding or pair of Alloys Are Processed ▶

Detecting ▶

Finished Product

Material Application and mechanical property

High speed steels

Grade	(%Chemical composition in%)										Standards		Hardness after annealing	Hardening temperature°C	QYEBGABT°C	tainable hardness HRC
	C	Cr	Mo	Ni	V	W	Co	Si	Mn	Others	DINEN	AISI				
S500	1.10	3.85	9.20	-	1.00	1.35	7.75	-	-	-	1.3427 HS2-10-1-8	M42	Max.280HB	1170-1210°C	(500-550°C)Oil,Vacuum,Salt bath(500-550°C)	67-69HRC
S600	0.91	4.05	5.00	-	1.75	6.20	-	-	-	-	1.3343,HS6-5-2-1.3554LW	-M2 reg.C	Max.280HB	1190-1230°C	(500-550°C)Oil,Vacuum,Salt bath(500-550°C)	64-66HRC
S705	0.92	4.05	4.95	-	1.85	6.20	4.75	-	-	-	1.34243 HS6-5-2-5	-M41	Max.280HB	1190-1230°C	(500-550°C)Salt bath,Gas	64-66HRC
S290	2.01	3.75	2.45	-	5.05	14.30	11.00	-	-	-	-	-	Max.350HB	1150-1210°C salt bath,1150-1190°C vacuum	(500-550°C)Oil,Vacuum,Salt bath(500-550°C)	66-70HRC
S390	1.64	4.75	2.00	-	4.80	10.40	7.98	-	-	-	-	-	Max.300HB	1150-1230°C	(500-550°C)Salt bath,Gas	65-69HRC
S590	1.29	4.20	5.00	-	3.03	6.33	8.40	-	-	-	1.3244 HS6-53-8	-	Max.300HB	1075-1180°C	(500-550°C)Salt bath,Gas	65-67HRC
S690	1.35	4.13	5.00	-	4.13	5.88	-	-	-	-	-1.3351-HS6-5-4	-M4	Max.280HB	1150-1200°C	(500-550°C)Salt bath,Gas	64-66HRC
S790	1.29	4.20	4.98	-	3.03	6.33	-	-	-	-	1.3345 HS6-5-3C	-M3CL2	Max.280HB	1050-1180°C	(500-550°C)Salt bath,Gas	

Hot work tool steels

Grade	(%Chemical composition in%)										Standards		Hardness after annealing	Hardening temperature°C	QYEBGABT°C	tainable hardness HRC	Aver. Rockwell C hardness after temp. at°C					
	C	Cr	Mo	Ni	V	W	Co	Si	Mn	Others	DINEN	AISI					400	500	550	600	650	700
V300	0.38	5.00	1.30	-	0.40	-	-	1.05	0.40	-	1.2343 X38CrMoV5-1	H11	205HB	1000-1040°C	Oil, Salt bath/Air, Vacuum(500-550°C)	52-56HRC 50-64HRC	53	54	52	48	38	30
V302	0.39	5.15	1.38	-	0.95	-	-	1.05	0.40	-	1.2344 X40CrMoV5-1	H13	205HB	1020-1080°C	Oil, Salt bath/Air, Vacuum(500-550°C)	52-56HRC 50-64HRC	54	55	54	50	40	32
W303	0.38	5.00	2.80	-	0.55	-	-	0.40	0.40	-	1.2367 X38CrMoV5-3	-	205HB	1030-1080°C	Oil, Salt bath/Air, Vacuum(500-550°C)	52-56HRC 50-64HRC	52	54	53	50	44	35
W350	0.38	5.00	1.75	-	0.55	-	-	0.20	0.55	N	-	-	205HB	1010-1020°C	Oil, Salt bath/Air, Vacuum(500-550°C)	52-54HRC 50-64HRC	52	53	53	47	45(620°C)	-
W360	0.50	4.50	3.00	-	0.60	-	-	0.20	0.25	-	-	-	205HB	approx.1050°C	Oil, Salt bath/Air, Vacuum(500-550°C)	52-57HRC recommended	See tempering chart					
W400	0.38	5.05	1.30	-	0.50	-	-	0.20	0.32	-	-1.2343-x37CrMoV5-1	-H11-	205HB	980-990°C	Oil, Salt bath/Air, Vacuum(500-550°C)	52-54HRC 50-53HRC	53	54	52	48	38	30
W403	0.38	5.00	2.80	-	0.65	-	-	0.20	0.25	-	-1.2367-X38CrMoV5-3	-	205HB	1020-1030°C	Oil, Salt bath/Air, Vacuum(500-550°C)	52-54HRC 50-53HRC	52	54	53	50	44	35



Material Application and mechanical property

Cold work tool steels

Grade	(%)Chemical composition in%										Standards		Hardness after annealing	Hardening temperature°C	QYEBGABT°C	tainable hardness HRC	Aver.Rockwell C hardness after temp. at°C						
	C	Cr	Mo	Ni	V	W	Co	Si	Mn	Others	DIN/EN	AISI					100	200	300	400	500	520	550
K107	2.10	11.50	-	-	-	0.70	-	0.25	0.38	-	1.2436 X210 CrW12	(-D6)	Max.205HB	950-980°C	Oil, Salt bath/Air, Vacuum(500-550°C)	64-66HRC	65	63	61	60	-	-	-
K110	1.55	11.25	0.75	-	0.75	-	-	0.30	0.30	-	1.2379 X155CrVMo12-1	D2	Max.205HB	1020-1040°C	Oil, Salt bath/Air, Vacuum(500-550°C)	63-65HRC	63	61	59	58	-	-	-
K340	1.10	8.25	2.10	-	0.50	-	-	0.90	0.40	+Al+Nb	-	-	Max.205HB	1040-1080°C	Oil, Salt bath/Air, Vacuum(500-550°C)	61-63HRC	See tempering chart						
K350	0.82	8.00	1.60	-	0.60	-	-	0.70	0.40	Al	-	-	Max.205HB	1030-1060°C	Oil, Salt bath, Vacuum(500-550°C)	57-62HRC	59(530°C)	58(540°C)	56	-	-	-	-
K390	2.47	4.23	3.80	0.21	9.00	1.00	2.00	0.55	0.42	-	-	-	Max.205HB	1030-1080°C	Oil, Vacuum	62-66HRC	See tempering chart						
K455	0.63	1.05	-	-	0.18	1.95	-	0.60	0.30	-	1.2550 60WC/V7	-S1	Max.205HB	870-900°C	Oil	58-62HRC	60	59	56	53	-	-	-
K460	0.95	0.55	-	-	0.10	0.55	-	0.25	1.10	-	1.2510 100MnCrW4	D1	Max.205HB	780-820°C	Salt bath,(200-250°C)	63-65HRC	64	62	58	52	-	-	-
K490	1.40	6.40	1.50	-	3.70	3.50	-	-	-	+Nb	-	-	Max.205HB	1030-1080°C	Oil, Salt bath, Vacuum	58-64HRC	62(540°C)	61	60(560°C)	57(570°C)	55(580°C)	-	-
K890	0.85	4.35	2.80	-	2.10	2.55	4.50	0.55	0.40	-	-	-	Max.205HB	1030-1180°C	Oil, Vacuum	58-64HRC	See tempering chart						

Plastic mould steels

Grade	(%)Chemical composition in%										Standards		Hardness after annealing	Hardening temperature°C	QYEBGABT°C	Tempering temperature°C	tainable hardness HRC
	C	Cr	Mo	Ni	V	W	Co	Si	Mn	Others	DIN/EN	AISI					
M238	0.38	1.95	0.20	1.10	-	-	-	0.30	1.45	-	1.2738 40CrMnNiMo8-6-4	~P20 mod	290-330HB 355-395HB Prehardend 290-330 HB or 355-395 HB(High Hard)	840-860°C			~30-35HRC ~38-42HRC
M268	0.38	2.00	0.20	1.10	-	-	-	0.50	1.50	-	1.2738	P20+Ni	355-395HB	840-860°C			~30-35HRC
M300	0.38	16.00	0.65	0.80	-	-	-	0.40	0.80	-	~1.2316-X42CrMo17	-	290-330HB	840-860°C			~30-35HRC
M303	0.28	14.45	0.95	0.85	-	-	-	0.25	0.65	+N	-	-	290-330HB Prehardened290-390HB				~30-35HRC
M310	0.38	14.45	-	-	0.20	-	-	0.70	0.43	-	~1.2083-x42Cr13	~420	Max.200HB	1000-1050°C	Gas,Salt ath,Oil	150-300/520-600°C	~48-52HRC
M315	0.045	12.60	-	-	-	-	-	0.30	0.93	S=0.10 Cu=0.40	-	-	290-330HB Prehardened290-390HB				~30-35HRC
M333	0.24	13.25	+	+	+	-	-	0.30	0.30	+N	-	-	Max.220HB	980-1000°C	Gas,Salt ath,Oil	150-300/520-600°C	~48-52HRC
M340	0.54	17.25	1.13	-	0.10	-	-	0.43	0.40	+N	-	-	Max.260HB	980-1000°C	Gas,Salt ath,Oil	150-300/520-600°C	~53-58HRC
M368	0.54	17.30	1.10	-	0.10	-	-	0.45	0.40	+N	-	-	Max.280HB	980-1000°C	Gas,Salt ath,Oil	150-300/520-600°C	~53-58HRC
M390	1.91	20.00	1.00	-	4.00	0.60	-	0.60	0.30	-	-	-	Max.280HB	1100-1180°C	Gas,Salt ath,Oil	150-300/520-600°C	~58-60HRC



Screw For Injection Molding Machine

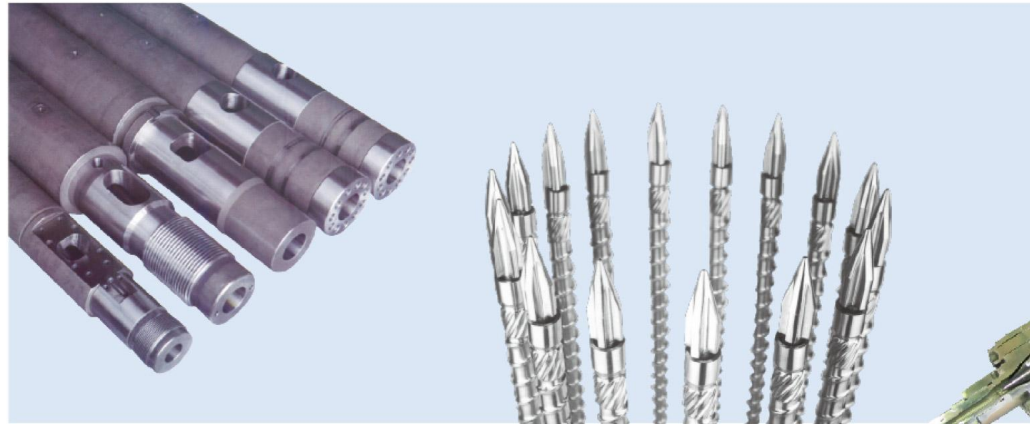

25-38000KN clamping force
30g-50000g injection unit



Screw For Injection Molding Machine



Screw&barrel use material

1. Material: 38CrMoAlA
Nitriding treatment. Surface hardness: HV2000
Nitriding depth: 0.5-0.8mm
2. Material: Special stainless steel
Vacuum quenching treatment, prolong life of parts.



规格参数 Specification parameter

(g) Amount of injection	(mm) screw diameter x length	(mm) barrel diameter x length	(g) Amount of injection	(mm) screw diameter x length	(mm) barrel diameter x length
30-90	Φ30x900	Φ85x860	800-1250	Φ75x1825	Φ170x1725
60-125	Φ35x910	Φ85x860	1000-1500	Φ80x2000	Φ180x1805
100-150	Φ38x935	Φ95x900	1250-2000	Φ85x2300	Φ190x1900
125-160	Φ40x980	Φ95x910	2000-3000	Φ90x2700	Φ210x2000
125-300	Φ42x1030	Φ105x1880	2500-5000	Φ100x2600	Φ230x2405
250-400	Φ45x1210	Φ115x1165	3000-6000	Φ110x2600	Φ256x2590
300-500	Φ50x1300	Φ125x1260	4000-10000	Φ120x2800	Φ256x2800
450-600	Φ55x1335	Φ130x1320	6000-8000	Φ130x3010	Φ256x2970
500-700	Φ56x1350	Φ130x1350	8000-10000	Φ145x3010	Φ256x3200
500-700	Φ60x1380	Φ140x1350	10000-15000	Φ160x3500	Φ270x3200
650-800	Φ65x1415	Φ150x1420	13000-25000	Φ170x3415	Φ317x3380
700-1000	Φ70x1790	Φ160x1685			



Screw & Barrel For Single Screw Extruder

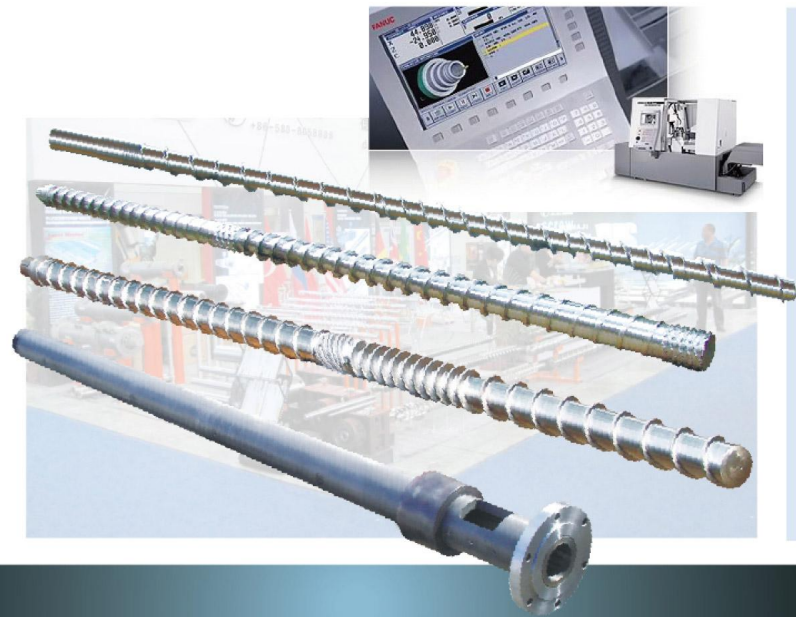

Screw & Barrel For Single Screw Extruder

PPPE high speed screw

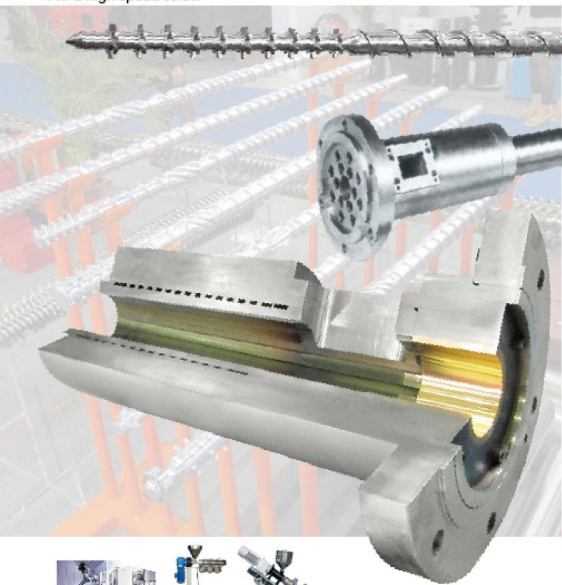

vacuum vented screw



For good plasticizing effect, we have different design of screw barrel to meet customer's demand. Gradual type, mutant type, wave type, barrier type, double screen type, shunt type, separation type, exhaust type, pin type, mixed type, double-head type, three-head type, multi head type etc.

Technical parameter

model	L/D	(kg/h) output capacity	(rpm) screw rotation speed	(kw) driving motor	(mm) Center heigh
20	20:1	3-5	10-60	1.1/1.5/2.2	1000-1400
ZS25	25:1	5-8	10-60	2.2/3.0/4.0	1000-1400
30	25:1	5-10	10-60	2.2/3.0/4.0	1000-1400
45	25-36:1	10-120	10-150	5.5-22	1000-1400
65	25-36:1	60-300	20-150	22-75	1000
75	25-36:1	200-450	20-150	30-132	1000
90	25-36:1	180-600	20-110	30-185	1000-1100
120	25-36:1	320-1000	20-90	75-280	1000-1250
150	25-36:1	400-1300	20-75	90-400	1000-1300



Conical Twin Screw & Barrel

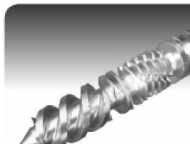

For Pipe (WPC) Extrusion



model	(kw) motor power	(mm) screw dia.	(rpm) screw rotation speed	PVC (kg/h)
45/90	15	45/90	34.7	60-80
50/105	18.5	51/105	34.7	80-100
55/110	22	55/110	34.7	120
65/132	30-37	65/132	34.7	150-250
80/156	55	80/156	34.7	250-400
92/188	110-132	92/188	34.7	500-700

model	(kw) motor power	(mm) screw dia.	(rpm) screw rotation speed	PVC (kg/h)
45/90	15	20	45	100
50/105	18.5	45/90	45	120
55/110	22	51/105	45	150
65/132	37	55/110	45	250
80/156	55	45	34.7	450
92/188	110	150	34.7	800



Technical parameter

For Pipe Extrusion

Conical Twin Screw & Barrel



Tungsten Carbide 0.5-52%

Parallel Twin Screw & Barrel

Technical parameter

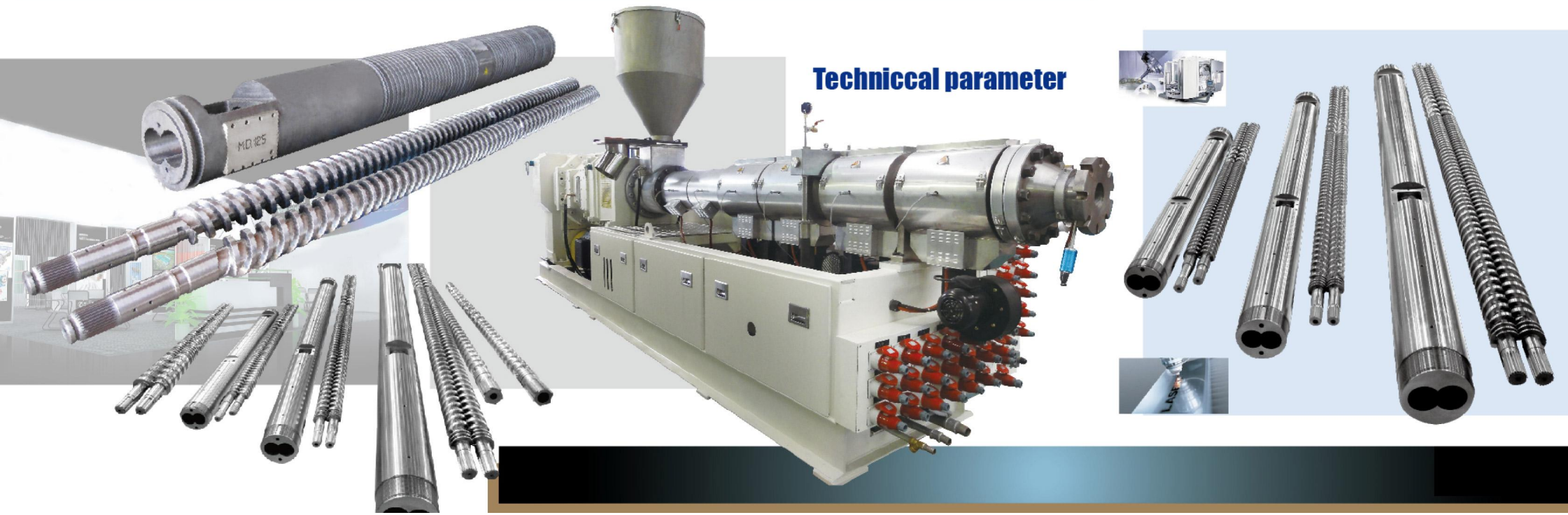

Parallel Twin Screw & Barrel



Technical parameter

model	motor power (kw)	screw dia. (mm)	L/D	screw rotation speed (rpm)	PVC (kg/h)
75	45	75	26-36	45	220-350
90	55	90	26-36	45	280-460
110	75	110	26-36	45	350-650
120	110	120	26-36	45	500-80
130	132	130	26-36	45	680-1000

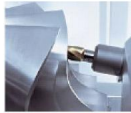

Rubber screw

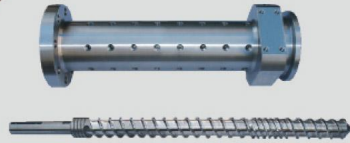

- 1.cool feeding rubber screw and barrel:
specification:Φ40-Φ300MM L/D=3-20
- 2.hot feeding rubber screw and barrel:
specification:Φ30-Φ250MM L/D=4-8
- 3.pin rubber screw and barrel:
specification:Φ60-Φ250MM
L/D=12-18



Techniccal parameter

	140	150	170	190		
(kw)	119	132	160	180	250	
(r/min)	3-60	3-60	3-60	3-60	3-60	
(kw)	7.5	7.5	11	11		
(dm3)	400	400	400	600	600	
PVC (Kg/h)Max	500	600	900	1100	1800	
PVC (Kg/h)Max		700	800	1100	1300	2000
PVC (Kg/h)Max	900	1000	1200	1500	2400	



PLANETRY SCREW BARREL

Gearboxes series



SJY, ZLYJ Serial Gearboxes for Plastic Single Screw Rod Extruder

SJY, ZLYJ Serial Gearboxes for Plastic and Rubber Single Screw Rod Extruder is a special reducer of the extruder researched and developed by combining actual condition of our country. They are widely used top and middle grade plastic, rubber and chemical fiber extruders.



ZLYJ Serial Gearboxes for Rubber Single Screw Rod Extruder

ZLYJ Serial Gearboxes for Rubber Single Screw Rod Extruder is a special driving reducer matched with rubber

Heater spare parts

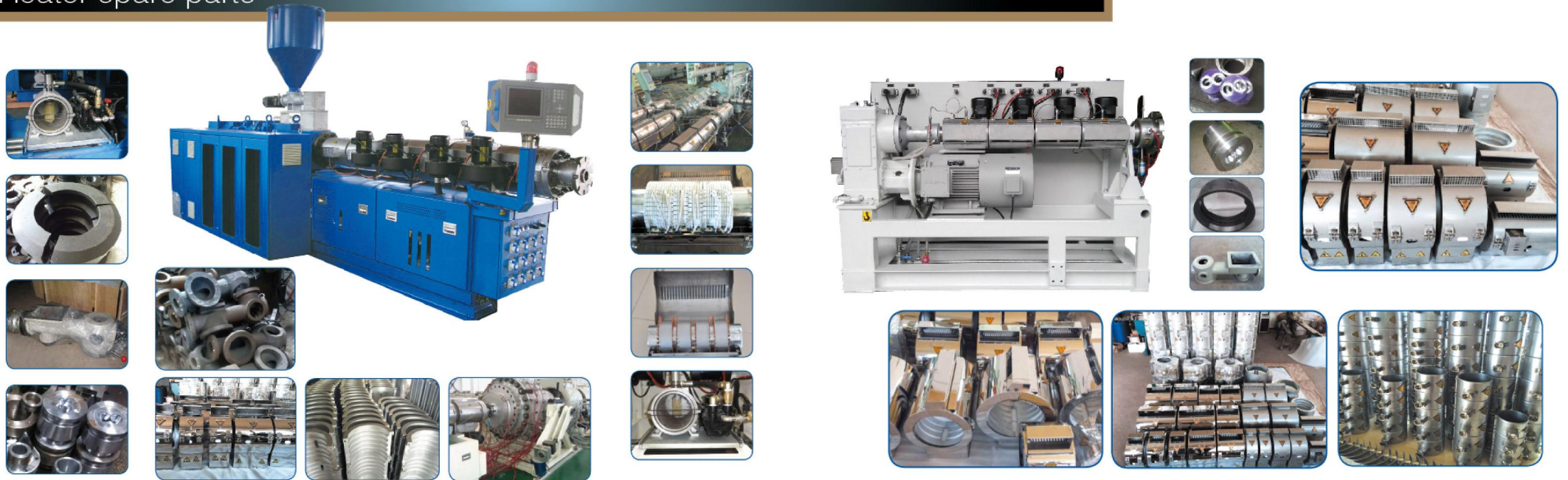

Mechanical accessories

The bimetallic screw and barrel

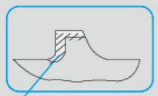
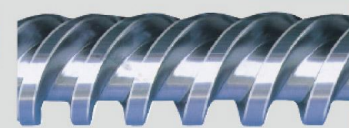

Alloy section of outputting

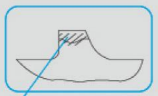

Alloy section of feeding and compressing

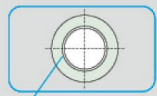

Alloy cover layer

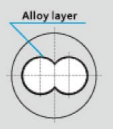

Alloy layer

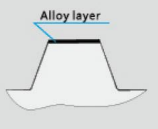

Alloy layer

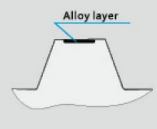

Alloy layer

The bimetallic barrel for single screw is a kind of barrel moulding 2-5mm-thick alloy coat on the barrel inner wall which has excellent corrosion resistance, abrasion resistance and high working temperatre.And its useful service life is greatly improved contrast to the common nitrided barrel. Bimetal has more obvious advantages when procesing special plastics to enhance the abrasion life, such as engineering plastics, fluorine plastics ,PPO,and etc.

The company uses special alloy powders being sprayed and welded on the screw's ridge,and used different alloys and welding methods for the screw of different functions.

The bimetallic screw and barrel

**powder metallurgy technology-bimetallic material-
Special Bimetallic steel -wear resistance and
corrosion resistance-improve 2-5 times working life**

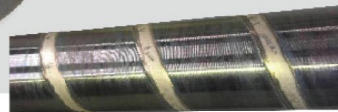
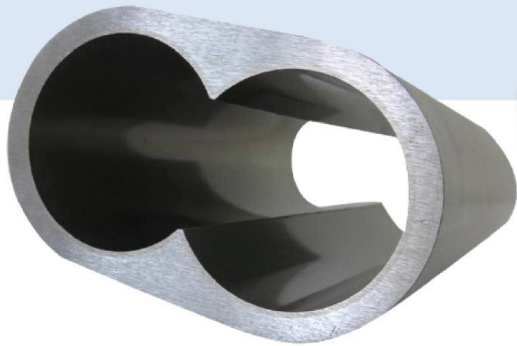

product category: bimetallic hole centrifugal casting barrel
Working Range: inner diameter 15mm-500mm, effective length: 8000mm
processing technic: HP/HVOF+Metallurgical Bonding
alloying component: Ni+Cr+Wc and so on
hardness scale: HRC62-64
adhesion power: >126MPa
straightness: 0.015mm/m
surface roughness: Ra0.4um
Alloy nameplate: Sweden
Product note: Patent all alloy sintering technology, super wear resistance, super corrosion resistance, it is suitable for halogen free material

The bimetallic screw and barrel



powder metallurgy technology-bimetallic material-Special Bimetallic steel -wear resistance and corrosion resistance-improve 2-5 times working life

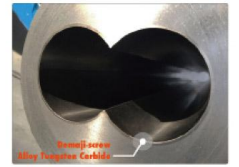
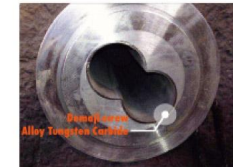
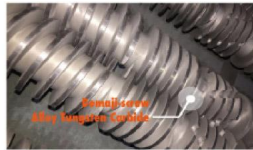
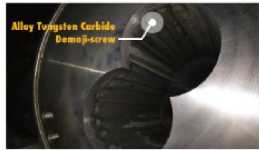

ADVANCED EQUIPMENT

